

RANGE COMPOSITION

Ideal for smaller sized catering establishments: bars, pubs, fast food outlets, pizzerias and small hotels; the Snack 600 range of modular cooking appliances consists of a series of appliances each with a depth of 600 mm - in gas and electric - featuring high power for fast service whether in table top situations, where space is a premium, or in a complete cooking installation, using the base units that can include doors, drawers or runners for gastronorm containers.



SCFE 700

SNACK 600

ELECTRIC RANGE **ZANUSSI** PROFESSIONAL

FUNCTIONAL AND CONSTRUCTION FEATURES

- ◆ Constructed completely in 18/10, 304 AISI stainless steel to guarantee a hard-wearing performance.
- ◆ Hygiene guaranteed by rounded edges, flush fit between units, side upstands and sealing joints, completely smooth and easy to clean surfaces and rear splashback.
- ◆ The top is pressed and perfectly sealed to prevent food infiltration.
- ◆ Cast-iron hot plates each with 2 kW power to ensure a rapid-heat up, sealed to the top. Temperature limiter to reduce energy consumption.
- ◆ Temperature control with 7 settings to suit all types of cooking.

ELECTRIC OVEN

- ◆ Electric fan assisted oven, oven chamber in stove enamelled sheet steel, internal lighting, removable self-cleaning panelling, thermostatically controlled temperature to 275°C. Timer.
- ◆ Grid and enamelled shelf supplied as standard.

- ◆ All models comply with the standards required by the main international approval bodies and are **CE** marked.

TECHNICAL DATA	
CHARACTERISTICS	MODELS
	SCFE700 285742
Power supply	Electric
External dimensions - mm	
width	700
depth	600
height	850
Power - kW	
installed-electric	10.5
Net weight - kg.	56
Supply voltage	400 V, 3N, 50/60
External dimensions - mm	
height adjustment	50
Oven cavity - mm	
width	460
depth	325
height	420
Power - kW	
oven	2,5
back plates	2,2
front plates	2,2

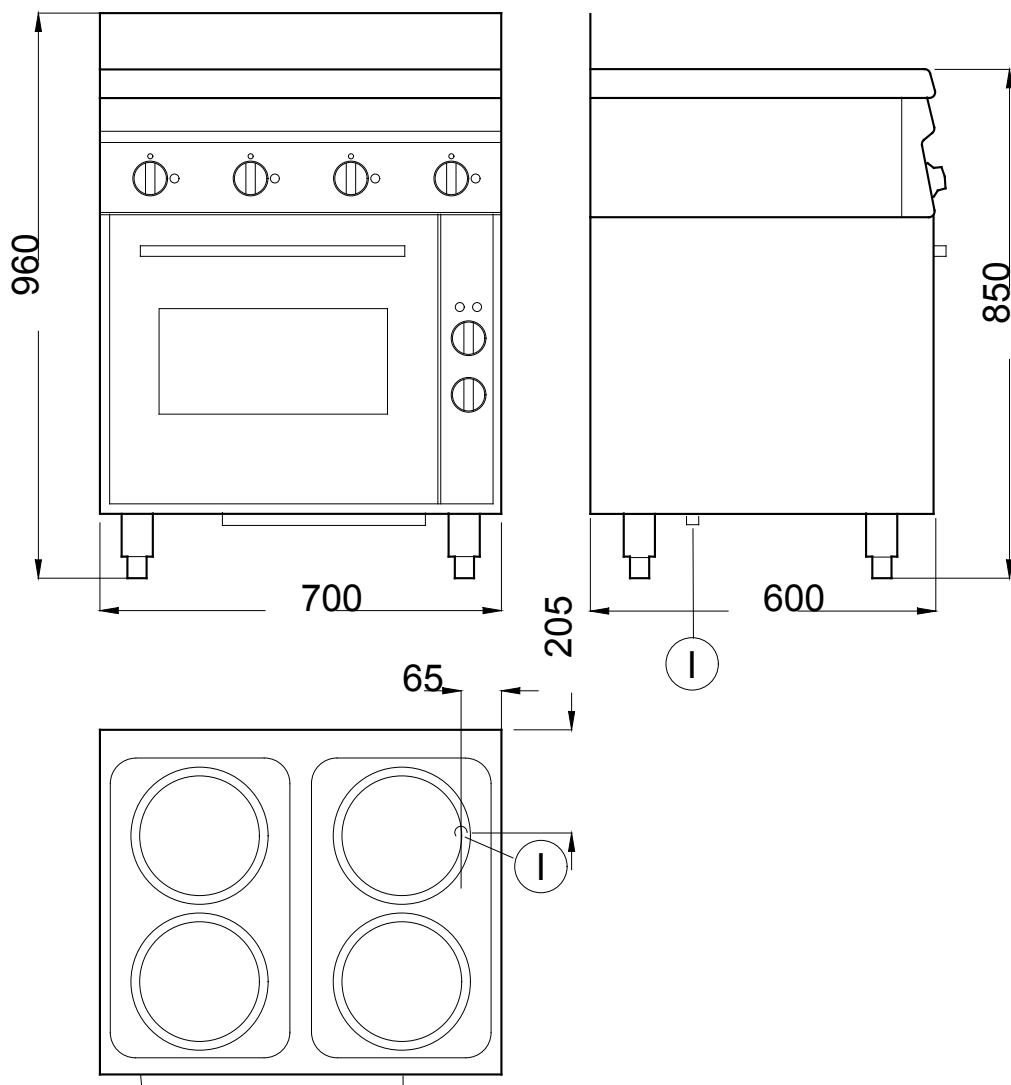

LEGEND	
I - Electrical connection	SCFE700 285742 400 V, 3N, 50/60



OPTIONAL ACCESSORIES	
ACCESSORIES	MODELS
GULLEY WITH JOINING PANEL FOR 600 LINE	SCFE700 285742 285798



www.zanussiprofessional.com